

COM Motion Estimation of a Humanoid Robot Based on a Fusion of Dynamics and Kinematics Information

Ken Masuya¹ and Tomomichi Sugihara²

Abstract—A novel Kalman filter to estimate the center of mass (COM) of a Humanoid robot is proposed. In the conventional works, COM was estimated by some methods. First one is the kinematics computation based on the mass property of the robot and the global position and attitude of the body frame, but those errors degrade the estimation accuracy. Second is the double integral of COM acceleration computed by the measured external force. However, its accuracy suffers from the error accumulation with the integration and the initial error remains. Third is based on the relationship between COM and the zero-moment point (ZMP), but it ignores the torque around COM. Additionally, it only dealt with the horizontal movement. For those problems, the proposed method combines those informations in order to improve the accuracy. Particularly, in order to estimate three dimensional motion of COM, the proposed method reduces the offset included in the vertical component by utilizing the interference between the horizontal and vertical component of COM shown in third information. Through the simulation, the improvement by the proposed method is verified.

I. INTRODUCTION

The efficacy of controlling the center of mass (COM) of a humanoid robot has been widely acknowledged. The behavior of COM captures the core of the whole body dynamics, and the idea is utilized in many works[1], [2], [3] in order to stabilize and maneuver the robot. The current COM is fed back to the controller at the same cycle as the control one. A common difficulty is that COM is determined from the mass distribution of the whole-body configuration, and thus, cannot be directly measured in principle.

In the previous studies[4], [5], [6], the position of COM is estimated by the forward kinematics computation on a robot whole-body model with the mass properties. A technique to identify the mass properties has also been developed[7]. This approach is also used in human motion analysis[7], [8]. The global positions and attitudes of each body segment can be measured by cameras in the case of motion capturing, while it is difficult for mobile robots. Two other options exist. Once the net force applied to the robot is measured, it turns to the acceleration of COM and the COM movement is estimated by the double integral of it[9]. However, the accuracy is

significantly degraded due to the error accumulation and the initial error. Another scheme is to use the relationship between COM and the center of pressure[4], [5], [10], [11], [12] which is also abbreviated as the zero-moment point (ZMP[13]). The behavior of ZMP resembles that of COM in the low frequency domain. Moreover, it matches the ground projection of COM at the stationary state, so that it is offset-free. One drawback is that it lacks the information about the vertical COM movement.

The goal of this paper is to present a novel technique to improve the estimation accuracy of the COM motion. The above three schemes, namely, the model-based forward kinematics computation, the double integral of the net external force, and the relationship between COM and ZMP, are integrated in a Kalman filter[14]. A position and attitude estimation technique that the authors[15], [16] developed enables the forward kinematics computation only from the inertial sensors and joint angle encoders. The third scheme of utilizing ZMP information is also improved, in which not only the horizontal offset but also the vertical one is compensated based on the interference of horizontal and vertical components of the ground reaction torque.

II. THREE SCHEMES OF COM MOTION ESTIMATION : REVIEW

In the previous works[4], [5], [6], [9], COM computation based on the kinematic model is the most popular technique as COM estimation. It needs not only the mass and COM of each link with respect to the body frame Σ_0 but also the position and attitude of Σ_0 with respect to the inertial frame Σ as shown in Fig. 1, so that COM of the robot with respect to Σ is computed as

$$\mathbf{p}_G = \frac{\sum_{i=0}^{n_l} m_i \mathbf{p}_{G,i}}{\sum_{i=0}^{n_l} m_i} = \mathbf{p}_0 + \mathbf{R}_0 \frac{\sum_{i=0}^{n_l} m_i {}^0\mathbf{p}_{G,i}}{\sum_{i=0}^{n_l} m_i}, \quad (1)$$

where $\mathbf{p}_G = [x_G \ y_G \ z_G]^T$ is COM of the robot with respect to Σ . m_i is the mass of i -th link and n_l is the total number of links. $\mathbf{p}_{G,i}$ and ${}^0\mathbf{p}_{G,i}$ denote COM of i -th link with respect to Σ and Σ_0 , respectively. \mathbf{p}_0 and \mathbf{R}_0 are the position and attitude of Σ_0 with respect to Σ , respectively. By differentiating Eq. (1) by time, COM velocity with respect to Σ is derived as

$$\mathbf{v}_G = \mathbf{v}_0 + \boldsymbol{\omega}_0 \times \mathbf{R}_0 \frac{\sum_{i=0}^{n_l} m_i {}^0\mathbf{p}_{G,i}}{\sum_{i=0}^{n_l} m_i} + \mathbf{R}_0 \frac{\sum_{i=0}^{n_l} m_i {}^0\mathbf{v}_{G,i}}{\sum_{i=0}^{n_l} m_i}, \quad (2)$$

*This work was supported by "Research and development of a disaster-response robot open-platform" (PI:Yoshihiko Nakamura) in International Research Development and Proof Project in Robotics / International Research Development and Proof Projects in Environment and Medicine, New Energy and Industrial Technology Development Organization.

¹K. Masuya is with the Department of Adaptive Machine Systems, Graduate School of Engineering, Osaka University, Japan ken.masuya@ams.eng.osaka-u.ac.jp

²T. Sugihara is with the Department of Adaptive Machine Systems, Graduate School of Engineering, Osaka University, Japan zhidao@ieee.org

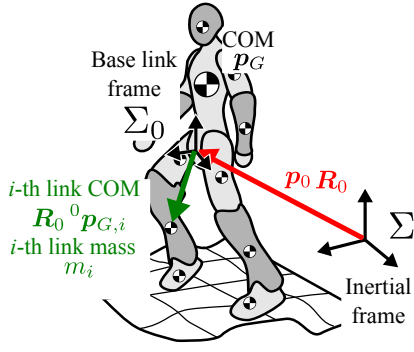

Fig. 1. The forward kinematics computation

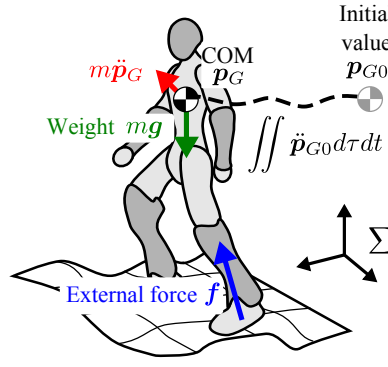

Fig. 2. The double integral of COM acceleration

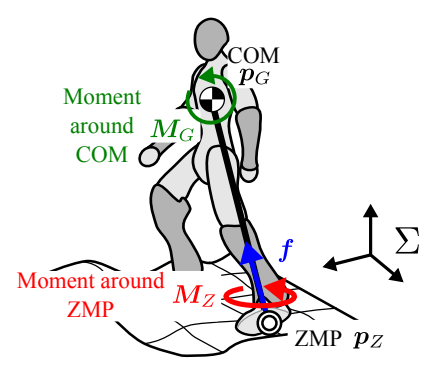

Fig. 3. The COM-ZMP model

where v_0 and ω_0 are the velocity and angular velocity of Σ_0 with respect to Σ , respectively. ${}^0v_{G,i}$ denotes COM velocity of i -th link with respect to Σ_0 . From Eqs. (1) and (2), the accuracy of p_G and v_G are deteriorated by the error included in the mass property, p_0 , v_0 , R_0 and ω_0 . The previous works[7], [8] identified the mass properties based on the motion measurement and least square regression, but the error of p_0 , v_0 , R_0 and ω_0 still remain. Under the assumption that the mass property of the robot is known, Xinjilefu et al.[5] proposed a Kalman filter based on the five-link model. Benallegue et al.[17] proposed a Kalman filter taking the flexibility of the supporting foot into consideration. Although those assume that the supporting foot is fixed on the ground during a step, the movement of the supporting foot can occur due to the foot contact condition and the robot motion.

Another option to estimate COM is the double integral of COM acceleration computed by the total external force acting to the robot[9] as shown in Fig. 2. Let $f = [f_x \ f_y \ f_z]^T$ be the total external force, the relationship between p_G and f is represented as

$$m\ddot{p}_G = f - mg, \quad (3)$$

where $g = [0 \ 0 \ g]^T$ and g is the acceleration due to the gravity. m is the total mass of the robot, which can be measured by the ground reaction force at the stationary state, and represented as $m = \sum_{i=0}^n m_i$. Thus, COM and its velocity are estimated as follows:

$$v_G = \int_0^t \left(\frac{f}{m} - g \right) d\tau + v_{G0}, \quad (4)$$

$$p_G = \int_0^t \left(\int_0^\tau \left(\frac{f}{m} - g \right) dT + v_{G0} \right) d\tau + p_{G0}, \quad (5)$$

where p_{G0} and v_{G0} are COM and its velocity with respect to Σ at the initial time $t = 0$, respectively. However, f is usually affected by the sensor noise, so that the error is accumulated by the integration. Additionally, it is clear that the initial errors included in p_{G0} and v_{G0} remains.

For those offset errors, it is reported that the idea based on ZMP is effective to the reduction of the horizontal offset[11], [12], [18], [4]. Benda et al.[11] and Caron et al.[12] estimated COM by low-pass filtering ZMP since ZMP corresponds to COM in the quasi-static state. However, it is only available

when COM moves slowly because of the low-pass filter (LPF). Schepers et al.[18] enlarged the available situation by combining low-pass filtered ZMP with high-pass filtered COM computed by the double integral of COM acceleration. However, the low frequency signal of the vertical position of COM is approximated as the position of pelvis, so that the estimated vertical COM has the offset error.

Another way to use ZMP is based on the idea that the motion of the humanoid robot is regarded as that of the linear inverted pendulum supported on ZMP[4], [5], [10] as shown in Fig. 3. This model is derived by the balance of force represented by Eq. (3) and that of moment represented as

$$(p_G - p_Z) \times f + M_G = M_Z, \quad (6)$$

$M_Z = [0 \ 0 \ M_{Zz}]^T$ and $M_G = [M_{Gx} \ M_{Gy} \ M_{Gz}]^T$ are the moment around ZMP and COM, respectively. $p_Z = [x_Z \ y_Z \ z_Z]^T$ is ZMP with respect to Σ . Assume that all external force and torque act to both feet and can be measured, p_Z and M_Z satisfy the following relationship:

$$M_Z = \sum_{i=1}^{n_s} ((p_{si} - p_Z) \times f_i + \tau_i), \quad (7)$$

where n_s is the total number of force sensors. $f_i = [f_{xi} \ f_{yi} \ f_{zi}]^T$ and $\tau_i = [\tau_{xi} \ \tau_{yi} \ \tau_{zi}]^T$ are the force and torque with respect to Σ measured at i -th force sensor's position $p_{si} = [x_{si} \ y_{si} \ z_{si}]^T$, respectively. In the practical measurement, i -th force sensor outputs 0f_i and ${}^0\tau_i$, which are the force and torque with respect to Σ_0 , and those coordinates are converted into Σ as

$$f_i = R_0 {}^0f_i, \quad \tau_i = R_0 {}^0\tau_i. \quad (8)$$

From the horizontal component of Eq. (7), ZMP is computed as

$$x_Z = \frac{\sum_{i=1}^{n_s} (-\tau_{yi} + x_{si}f_{zi} - (z_{si} - z_Z)f_{xi})}{\sum_{i=1}^{n_s} f_{zi}}, \quad (9)$$

$$y_Z = \frac{\sum_{i=1}^{n_s} (\tau_{xi} + y_{si}f_{zi} - (z_{si} - z_Z)f_{yi})}{\sum_{i=1}^{n_s} f_{zi}}, \quad (10)$$

where z_Z is usually determined arbitrarily. Assume that $M_G \approx 0$, the motion equation of COM is represented as

$$\begin{bmatrix} \ddot{x}_G \\ \ddot{y}_G \end{bmatrix} = \begin{bmatrix} \zeta^2 (x_G - x_Z) \\ \zeta^2 (y_G - y_Z) \end{bmatrix}, \quad (11)$$

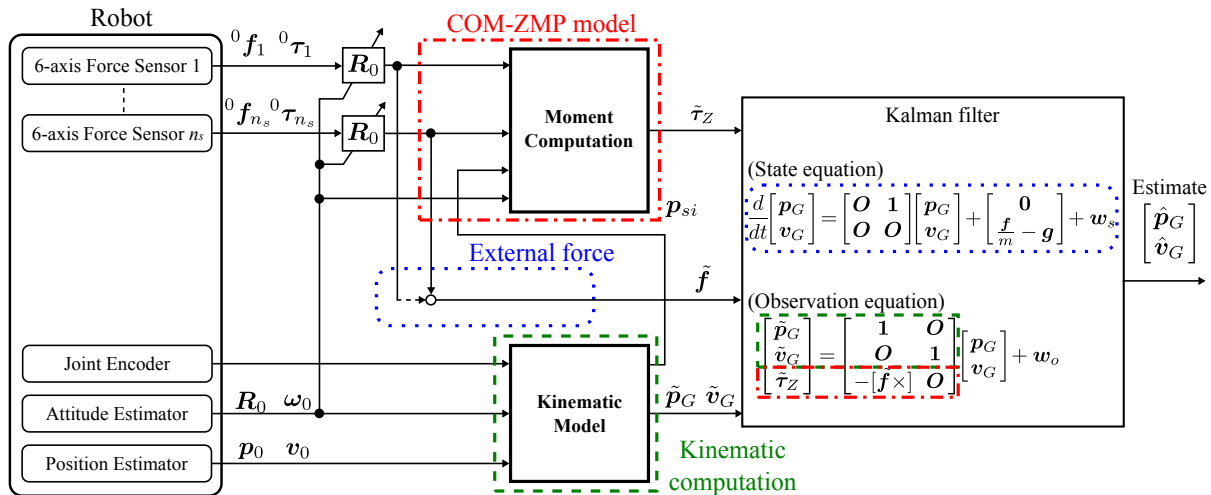

Fig. 4. The overview of the proposed method (red line, blue line and green line are related to COM-ZMP model, the external force and the kinematic model, respectively.)

where $\zeta = \sqrt{(\ddot{z}_G + g)/(z_G - z_Z)}$. Hereafter, the relationship between COM and ZMP in which M_G is ignored is called COM-ZMP model. Additionally, the estimation based on the form as shown in Eq. (11) only dealt with the horizontal motion.

In order to improve the accuracy of vertical COM, the ankle joint based COM estimations were proposed[6], [19] under the assumption that the supporting foot is fixed on the ground during a step. By regarding the relationship between COM and the ankle joint of the supporting foot as the flexible inverted pendulum model, Kwon et al.[6] estimated COM indirectly. Barbier et al.[19] computed COM based on the inverted pendulum model supported on the ankle joint with a constant length. Although those methods show that the idea of the inverted pendulum is effective in the vertical COM estimation, the assumption about the supporting foot is not always satisfied.

III. COM ESTIMATION BY KALMAN FILTER FUSING THE DYNAMICS AND KINEMATICS INFORMATION

Following the previous section, this paper aims to improve the accuracy of three dimensional COM estimation of a humanoid robot based on the inverted pendulum model. The pendulum supported on the ankle joint has the limit about the supporting foot, so that this paper considers the pendulum supported on ZMP, namely, COM-ZMP model. Although one method to use COM-ZMP model is to employ Eq. (11) as the time evolution model, there is the problem that both side of Eq. (11) has the second derivative of COM. Then, we focus on COM-ZMP model without the derivative, namely, the moment equilibrium represented as Eq. (6). By substituting Eq. (7) to Eq. (6), the moment equilibrium is rewritten as

$$-[\mathbf{f} \times] \mathbf{p}_G = \boldsymbol{\tau}_Z - \mathbf{M}_G, \quad (12)$$

where

$$\boldsymbol{\tau}_Z \equiv \sum_{i=1}^{n_s} (\mathbf{p}_{si} \times \mathbf{f}_i + \boldsymbol{\tau}_i), \quad (13)$$

and $[\mathbf{f} \times]$ is a skew-symmetric matrix which means the cross product by \mathbf{f} . As well as the previous works using ZMP[4], [5], [10], this paper assumes that M_G is negligible, so that Eq. (12) is approximated as

$$-[\mathbf{f} \times] \mathbf{p}_G \simeq \boldsymbol{\tau}_Z. \quad (14)$$

It is noticed that Eq. (14) no longer includes ZMP, but it is a broad COM-ZMP model in the sense that M_G is ignored. Although Eq. (14) is an algebraic equation representing COM-ZMP model unlike Eq. (11), its solution is non-unique. One method to get the unique solution is to put the assumption that the length of pendulum is constant as well as Barbier et al.[19], but the assumption is not applicable to even COM motion with the same height.

This paper resolves that problem by combining COM from the kinematics computation, the external force and COM-ZMP model based on Kalman filter. Fig. 4 shows the overview of the proposed method. COM from the kinematics computation is represented by only informations at the current time, so that it is used as a part of the observation equation. COM-ZMP model represented by Eq. (12) also uses only the current force and torque, so that this paper employs the model as the part of the observation equation though the coefficient matrix includes the noise. On the other hand, since the double integral of COM acceleration is derived from a differential equation represented by Eq. (3), COM from the external force is suitable for a state equation. Thus, the state and observe equation for the proposed Kalman filter is represented as

$$\dot{\mathbf{x}} = \begin{bmatrix} \mathbf{O} & \mathbf{1} \\ \mathbf{O} & \mathbf{O} \end{bmatrix} \mathbf{x} + \begin{bmatrix} \mathbf{0} \\ \frac{\tilde{\mathbf{f}}}{m} - \mathbf{g} \end{bmatrix} + \mathbf{w}_s, \quad (15)$$

$$\mathbf{y} = \begin{bmatrix} \mathbf{1} & \mathbf{O} \\ \mathbf{O} & \mathbf{1} \\ -[\tilde{\mathbf{f}} \times] & \mathbf{O} \end{bmatrix} \mathbf{x} + \mathbf{w}_o, \quad (16)$$

where $\mathbf{x} = [\mathbf{p}_G^T \ \mathbf{v}_G^T]^T$ is the state vector. $\mathbf{y} = [\tilde{\mathbf{p}}_G^T \ \tilde{\mathbf{v}}_G^T \ \tilde{\boldsymbol{\tau}}_Z^T]^T$ is the measurement vector and $\tilde{\ast}$ means the measurement of

the variable $*$. \mathbf{O} , $\mathbf{1} \in \mathbb{R}^{3 \times 3}$ and $\mathbf{0} \in \mathbb{R}^3$ are the zero matrix, the identity matrix and the zero vector, respectively. In the actual estimation, it is also necessary to estimate \mathbf{p}_0 , \mathbf{v}_0 , \mathbf{R}_0 and $\boldsymbol{\omega}_0$ for the kinematics computation and the coordinate transformation, so that they are assumed to be obtained by the attitude estimator[15] and the position estimator[16] in advance.

IV. EVALUATION THROUGH THE SIMULATION

A. Discretization of Kalman filter for the implementation

It is necessary to discretize the proposed Kalman filter in order to implement it. The forward finite-difference approximation is employed due to its simplicity, thus the proposed filter is discretized as

$$\mathbf{x}_{k+1} = \mathbf{A}\mathbf{x}_k + \mathbf{u}_k + \mathbf{w}_{sk}\Delta T, \quad (17)$$

$$\mathbf{y}_k = \mathbf{C}_k\mathbf{x}_k + \mathbf{w}_{ok}, \quad (18)$$

$$\mathbf{A} = \begin{bmatrix} \mathbf{1} & \Delta T\mathbf{1} \\ \mathbf{O} & \mathbf{1} \end{bmatrix}, \quad \mathbf{u}_k = \begin{bmatrix} \mathbf{0} \\ \Delta T \left(\frac{\tilde{\mathbf{f}}_k}{m} - \mathbf{g} \right) \end{bmatrix},$$

$$\mathbf{C}_k = \begin{bmatrix} \mathbf{1} & \mathbf{O} \\ \mathbf{O} & \mathbf{1} \\ -[\tilde{\mathbf{f}}_k \times] & \mathbf{O} \end{bmatrix}.$$

ΔT is the sampling time and the subscript k means the index of the discrete time $k\Delta T$. Therefore, the algorithm of measurement update is written as

$$\mathbf{K}_k = \mathbf{P}_{k|k-1}\mathbf{C}_k^T (\mathbf{C}_k\mathbf{P}_{k|k-1}\mathbf{C}_k^T + \mathbf{Q}_o)^{-1}, \quad (19)$$

$$\hat{\mathbf{x}}_{k|k} = \hat{\mathbf{x}}_{k|k-1} + \mathbf{K}_k (\mathbf{y}_k - \mathbf{C}_k\hat{\mathbf{x}}_{k|k-1}), \quad (20)$$

$$\mathbf{P}_{k|k} = \mathbf{P}_{k|k-1} - \mathbf{K}_k\mathbf{C}_k\mathbf{P}_{k|k-1}, \quad (21)$$

where $\hat{\mathbf{x}}_{k|k}$ and $\hat{\mathbf{x}}_{k|k-1}$ mean the estimates of \mathbf{x}_k from the information until $k\Delta T$ and $(k-1)\Delta T$, respectively. $\mathbf{P}_{k|k}$ and $\mathbf{P}_{k|k-1}$ are the error covariance matrices of $\hat{\mathbf{x}}_{k|k}$ and $\hat{\mathbf{x}}_{k|k-1}$, respectively. \mathbf{Q}_o is the covariance matrix of \mathbf{w}_o . On the other hand, the algorithm of time update is written as

$$\hat{\mathbf{x}}_{k+1|k} = \mathbf{A}\hat{\mathbf{x}}_{k|k} + \mathbf{u}_k, \quad (22)$$

$$\mathbf{P}_{k+1|k} = \mathbf{A}\mathbf{P}_{k|k}\mathbf{A}^T + \mathbf{Q}_s, \quad (23)$$

where \mathbf{Q}_s is the covariance matrix of $\mathbf{w}_s\Delta T$.

B. Set up

In order to evaluate the validity of the proposed method, the dynamic simulation was executed on OpenHRP3[21]. In the simulation, a humanoid robot named "mighty" [20] was supposed as the robot model. Each foot of the robot has 4 force sensors on its sole. PD controller was employed to evaluate only the estimation performance and used the references of joint angles and those differential which are computed by Sugihara's method[22] in advance. We considered the walking motion which stride length and walking cycle were set to 0.08[m] and 1[s], respectively. In the motion, the robot first stop until 2[s], then walks forward. Snapshots of the motion are shown in Fig. 5. We set the forward, leftward and vertical direction at the initial time as x , y and z direction, respectively.

In order to imitate the sensor noise, following noises were input to the true values in the estimation.

$$\mathbf{w}_f \sim \mathcal{N}(\boldsymbol{\mu}_f, \text{diag}\{0.17^2, 0.17^2, 0.34^2\}),$$

$$\boldsymbol{\mu}_f \sim \mathcal{N}(\mathbf{0}, \text{diag}\{0.5^2, 0.5^2, 1.0^2\}), \quad (24)$$

$$\mathbf{w}_\tau \sim \mathcal{N}(\boldsymbol{\mu}_\tau, 0.0034^2\mathbf{1}), \quad \boldsymbol{\mu}_\tau \sim \mathcal{N}(\mathbf{0}, 0.01^2\mathbf{1}), \quad (25)$$

where \mathbf{w}_f [N] and \mathbf{w}_τ [Nm] are the noise adding to the force and torque, respectively. $\boldsymbol{\mu}_f$ [N] and $\boldsymbol{\mu}_\tau$ [Nm] mean the offset of the measured force and torque, respectively. $\mathcal{N}(\boldsymbol{\mu}, \boldsymbol{\Sigma})$ means the normal distribution with the mean $\boldsymbol{\mu}$ and the covariance matrix $\boldsymbol{\Sigma}$. $\text{diag}\{d_1, \dots, d_n\}$ is the diagonal matrix which components are d_1, \dots, d_n . Third covariance of \mathbf{w}_f was determined so that three times values of it is equal to a 2[%] weight. First and second element are set to be a half of third element. The covariance of \mathbf{w}_τ is also determined based on that third element. The covariances of $\boldsymbol{\mu}_f$ and $\boldsymbol{\mu}_\tau$ were determined so that those values are about three times values of the covariance of \mathbf{w}_f and \mathbf{w}_τ , respectively. $\boldsymbol{\mu}_f$ and $\boldsymbol{\mu}_\tau$ were initialized at the beginning of the simulation. Next, in order to take differences between the mass properties of the modeled and real robot into consideration, the following erroneous mass properties are employed in the estimation.

$$\tilde{m}_i = (1 + w_m)m_i, \quad w_m \sim \mathcal{N}(0, 0.2), \quad (26)$$

$$\tilde{\mathbf{p}}_{Gi} = (1 + w_G)\mathbf{p}_{Gi}, \quad w_G \sim \mathcal{N}(0, 0.3), \quad (27)$$

where \tilde{m}_i and $\tilde{\mathbf{p}}_{Gi}$ are the erroneous mass and COM of i -th link, respectively. It is noticed that references given to controller are computed based on this erroneous mass properties. Additionally, noise of the rate gyro, the accelerometer and the magnetometer, which are used for the attitude estimator and the position estimator, were added to the ground truth of the angular velocity, acceleration and magnetism. Those noises are represented as follow:

$$\mathbf{w}_\omega \sim \mathcal{N}(\boldsymbol{\mu}_\omega, 0.03^2\mathbf{1}), \quad \boldsymbol{\mu}_\omega \sim \mathcal{N}(\mathbf{0}, 0.03^2\mathbf{1}) \quad (28)$$

$$\mathbf{w}_a \sim \mathcal{N}(\boldsymbol{\mu}_a, 0.04^2\mathbf{1}), \quad \boldsymbol{\mu}_a \sim \mathcal{N}(\mathbf{0}, 0.01^2\mathbf{1}) \quad (29)$$

$$\mathbf{w}_n \sim \mathcal{N}(\mathbf{0}, 0.013^2\mathbf{1}), \quad (30)$$

where \mathbf{w}_ω [rad/s], \mathbf{w}_a [m/s²] are the noise of the rate gyro and the accelerometer, respectively. \mathbf{w}_n is the noise added to the unit vector corresponding to the direction of the true output of the magnetometer. $\boldsymbol{\mu}_\omega$ [rad/s] and $\boldsymbol{\mu}_a$ [m/s²] are the offset bias of the rate gyro and the accelerometer, respectively. Those offsets are initialized at the beginning of each simulation.

In the simulation, the following methods were compared:

- Kinematics computation with fixed supporting foot based dead reckoning (KC)
- Kinematics computation with the position estimator (KC+Pos.Est.)
- Kalman filter without COM-ZMP model (KF wo. COM-ZMP)
- The proposed Kalman filter (PKF)

In order to verify that the effect of the accuracy of \mathbf{p}_0 to COM estimation, we considered KC. The position and velocity of Σ_0 were estimated by the position estimator[16]

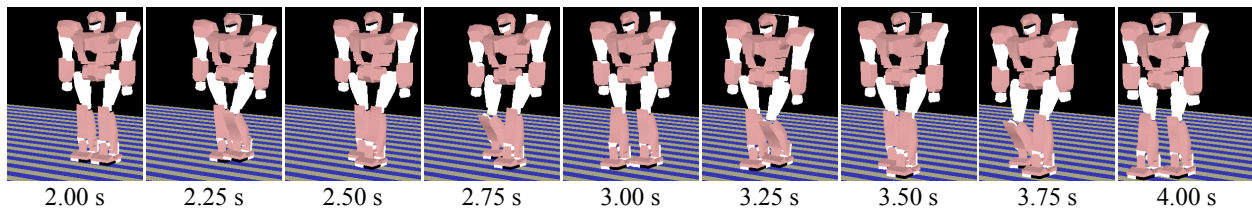
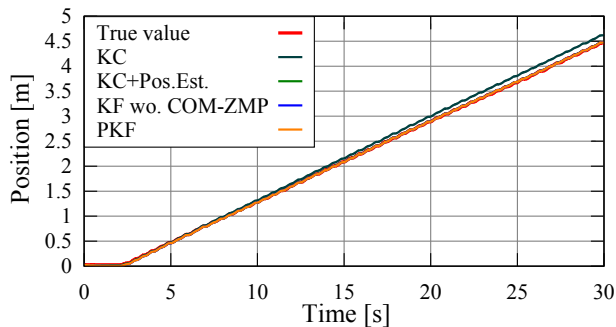
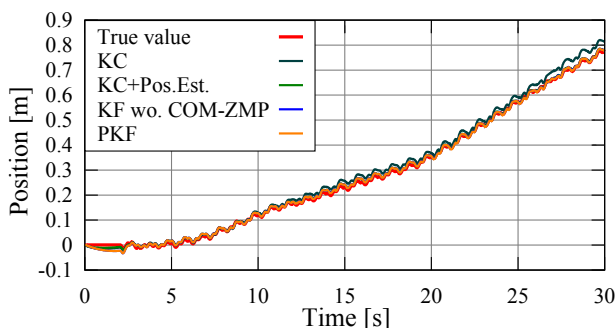

Fig. 5. Snapshots of walking on the horizontal plane



(a) x -direction



(b) y -direction

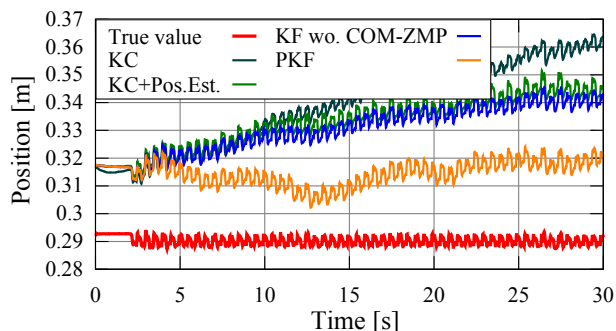

(c) z -direction

Fig. 6. A result of COM position estimation

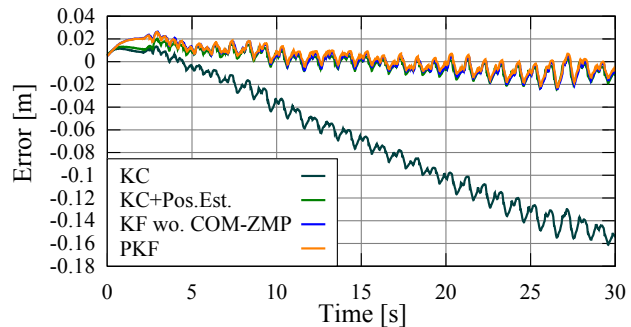

(a) x -direction

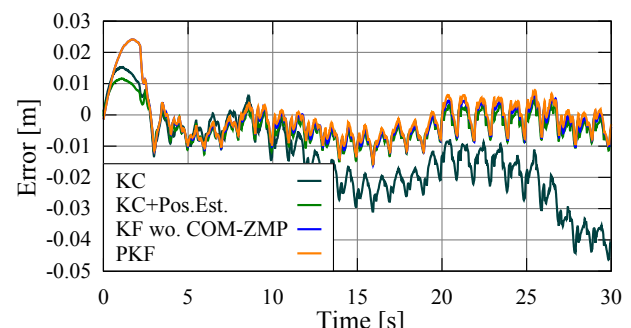

(b) y -direction

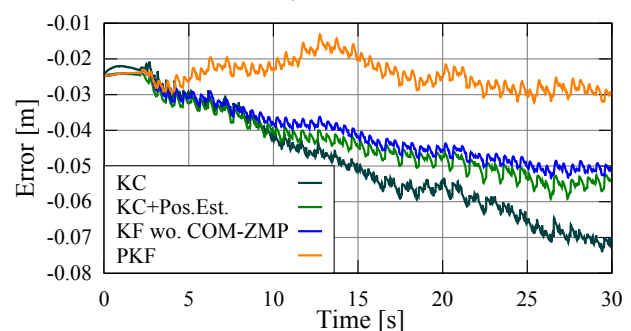

(c) z -direction

Fig. 7. An error result of COM position estimation

except for KC. Also, in all methods, the attitude information was estimated by the author's previous work[15]. Parameters for PKF were determined based on the error property of the force sensor and the mass property. Parameters of KF wo. COM-ZMP are the same as the corresponding parameter of PKF.

C. Simulation result

A result of estimation and its error result are plotted in Figs. 6 and 7, respectively. The mean of the absolute value of mean error (MAME) and the root-mean square error (RMSE)

of the estimated COM position for 10 noise patterns are shown in Table I. MAME is used to evaluate the mean error for the whole simulation and is computed as

$$\text{MAME}(e_G) = \frac{1}{10} \sum_{i=0}^{10} \left| \frac{1}{N} \sum_{k=1}^N e_{G,i,k} \right|, \quad (31)$$

where $e_{G,i,k}$ is the error of COM at $k\Delta T$ in i -th error pattern. N is the total number of steps in a simulation. On the other hand, RMSE is employed to evaluate the total error including both the mean and variance of the error and is

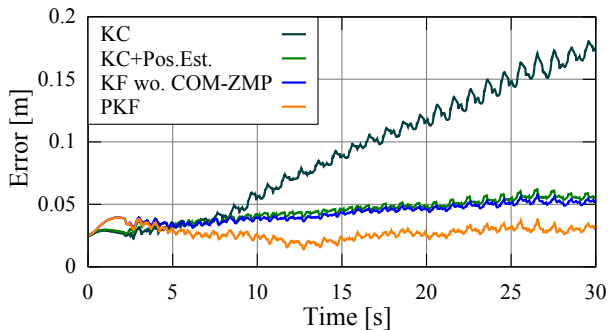

Fig. 8. An example of the norm of the error

TABLE I
THE ESTIMATION ERROR

	MAME [$\times 10^{-3}$ m]			RMSE [$\times 10^{-3}$ m]		
	x	y	z	x	y	z
KC	86.8	19.0	25.7	97.7	22.7	30.4
KC+Pos. Est.	4.61	7.37	14.6	7.86	10.3	19.8
KF wo. COM-ZMP	5.08	6.79	14.2	8.66	9.85	18.6
PKF	5.56	6.49	10.3	9.35	9.57	12.6

computed as

$$\text{RMSE}(e_G) = \sqrt{\frac{1}{10} \sum_{i=0}^{10} \left(\frac{1}{N} \sum_{k=1}^N e_{G,i,k}^2 \right)}. \quad (32)$$

The comparison KC with others shows that the error of the global position is dominant for COM estimation, particularly, in x direction. Compared with KC+Pos.Est., the proposed method and KF wo. COM-ZMP can reduce both MAME and RMSE in y direction, but those in x direction increase. This is because of the noise of the force sensor. Focusing on the result of z direction, the proposed method is the best estimation. Compared with KC+Pos.Est., the proposed method shows about 30[%] reduction in MAME and about 35[%] reduction in RMSE. This reduction makes the error norm of PKF smaller as shown in Fig. 8. Thus, PKF can improve the estimation accuracy in z direction.

V. CONCLUSION

This paper proposes a novel Kalman filter to estimate COM motion of a humanoid robot. It combines COM from the kinematic model, the external force and a broad COM-ZMP model. In order to reduce the vertical offset, the filter uses the interference between the horizontal and vertical component caused by COM-ZMP model. Through the simulation in which the robot walks on the plane, it is ensured that the proposed method can reduce the offset error in COM position estimation.

REFERENCES

- [1] K. Mitobe, G. Capi and Y. Nasu, "Control of walking robots based on manipulation of the zero moment point," *Robotica*, vol.18, no.6, pp.651–657, 2000.
- [2] T. Sugihara, Y. Nakamura and H. Inoue, "Realtime Humanoid Motion Generation through ZMP Manipulation based on Inverted Pendulum Control," in Proc. of the 2002 IEEE Int. Conf. on Robotics and Automation, Washington, DC, USA, 2002, pp. 1404–1409.
- [3] T. Sugihara, "Standing Stabilizability and Stepping Maneuver in Planar Bipedalism based on the Best COM-ZMP Regulator," in Proc. of the 2002 IEEE Int. Conf. on Robotics and Automation, Kobe, Japan, 2009, pp. 1966–1971.
- [4] B. J. Stephens, "State estimation for force-controlled humanoid balance using simple models in the presence of modeling error," in Proc. of the 2011 IEEE Int. Conf. on Robotics and Automation, Shanghai, China, 2011, pp. 3994–3999.
- [5] Xinjilefu and C. G. Atkeson, "State Estimation of a Walking Humanoid Robot," in Proc. of 2012 IEEE/RSJ Int. Conf. on Intelligent Robots and Systems, Vilamoura, Algarve, Portugal, 2012, pp. 3693–3699.
- [6] S.J. Kwon and Y. Oh, "Real-Time Estimation Algorithm for the Center of Mass of a Bipedal Robot with Flexible Inverted Pendulum Model," in Proc. of the 2009 IEEE/RSJ Int. Conf. on Intelligent Robots and Systems, St. Louis, USA, 2009, pp. 5463–5468.
- [7] S. Cotton, A. P. Murray and P. Fraithe, "Estimation of the Center of Mass: From Humanoid Robots to Human Beings," *IEEE/ASME Trans on Mechatronics*, vol.14, no.6, pp. 707–712, 2009.
- [8] G. Venture, K. Ayusawa and Y. Nakamura, "Motion Capture Based Identification of The Human Body Inertial Parameters," in Proc. of 30th Annual Int. Conf. of the IEEE Engineering in Medicine and Biology Society, Vancouver, British Columbia, Canada, 2008, pp.4575–4578.
- [9] J. J. Eng and D. A. Winter, "Estimations of the horizontal displacement of the total body centre of mass: considerations during standing activities," *Gait & Posture*, vol.1, no.3, pp. 141–144, 1993.
- [10] I. Hashlamon and K. Erbaturo, "Center of Mass States and Disturbance Estimation for a Walking Biped", In Proc. of 2013 IEEE Int. Conf. on Mechatronics, Vicenza, Italy, 2013, pp. 248–253.
- [11] B. J. Benda, P. O. Riley and D. E. Krebs, "Biomechanical relationship between center of gravity and center of pressure during standing," *IEEE Trans. on Rehabilitation Engineering*, vol.2, no.1, pp. 3–10, 1994.
- [12] O. Caron, B. Faure and Y. Brenière, "Estimating the centre of gravity of the body on the basis of the centre of pressure in standing posture," *J. of Biomechanics*, vol.30, pp. 1169–1171, 1997.
- [13] M. Vukobratović and J. Stepanenko, "On The Stability of Anthropomorphic Systems," *Mathematical Biosciences*, vol.15, no.1, pp. 1–37, 1972.
- [14] R. E. Kalman, "A New Approach to Linear Filtering and Prediction Problems," *Trans. of the ASME. Series D, Journal of Basic Engineering*, Vol.82, pp.35–45, 1960.
- [15] K. Masuya, T. Sugihara and M. Yamamoto, "Design of Complementary Filter for High-fidelity Attitude Estimation based on Sensor Dynamics Compensation with Decoupled Properties," in Proc. of the 2012 IEEE Int. Conf. on Robotics and Automation, St. Paul, Minnesota, USA, 2012, pp.606–611.
- [16] K. Masuya and T. Sugihara, "Dead reckoning for biped robots that suffers less from foot contact condition based on anchoring pivot estimation," *Advanced Robotics*, Vol.29, No.12, pp.785–799, 2015.
- [17] M. Benallegue and F. Lamiroux, "Humanoid Flexibility Deformation Can Be Efficiently Estimated Using Only Inertial Measurement Units and Contact Information," Proc. of the 14th IEEE-RAS Int. Conf. on Humanoid Robots, Madrid, Spain, 2014, pp.246–251.
- [18] H. M. Schepers, E. H. F. van Asseldonk, J. H. Burke and P. H. Veltink, "Ambulatory Estimation of Center of Mass Displacement During Walking," *IEEE Trans. on Biomedical Engineering*, vol.56, no.4, pp. 1189–1195, 2009.
- [19] F. Barbier, P. Allard, K. Guelton, B. Colobert and AP. Godillon-Maquinghen, "Estimation of the 3-D Center of Mass Excursion From Force-Plate Data During Standing," *IEEE Trans. on Neural Systems and Rehabilitation Engineering*, Vol.11, No.1, pp.31–37, 2003.
- [20] T. Sugihara, K. Yamamoto and Y. Nakamura, "Hardware design of high performance miniature anthropomorphic robots," *Robotics and Autonomous System*, vol.56, no.1, pp. 82–94, 2007.
- [21] S. Nakaoka, S. Hattori, F. Kanehiro, S. Kajita and H. Hirukawa, "Constraint-based Dynamics Simulator for Humanoid Robots with Shock Absorbing Mechanisms," in Proc. of the 2007 IEEE/RSJ Int. Conf. on Intelligent Robots and Systems, San Diego, CA, USA, 2007, pp. 3641–3647.
- [22] T. Sugihara and Y. Nakamura, "Boundary Condition Relaxation Method for Stepwise Pedipulation Planning of Biped Robots," *IEEE Trans. on Robotics*, vol.25, no.3, pp.658–669, 2009.